

Parts Included:

HALF SIZE PANEL BRACKET KIT

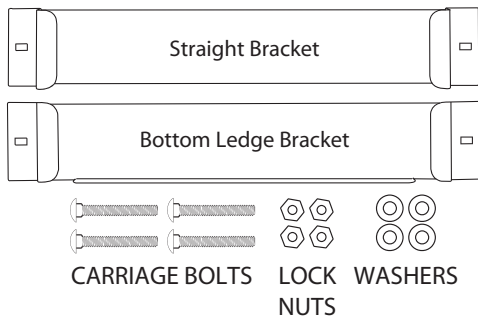

FULL SIZE PANEL BRACKET KIT

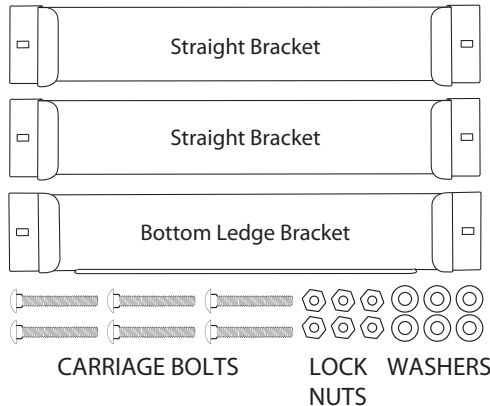

Tools Needed:

¼" BOX, OPEN-ENDED OR ADJUSTABLE WRENCH

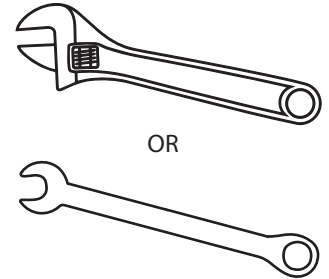

Installing Full Size Panel Bracket Kit A240510

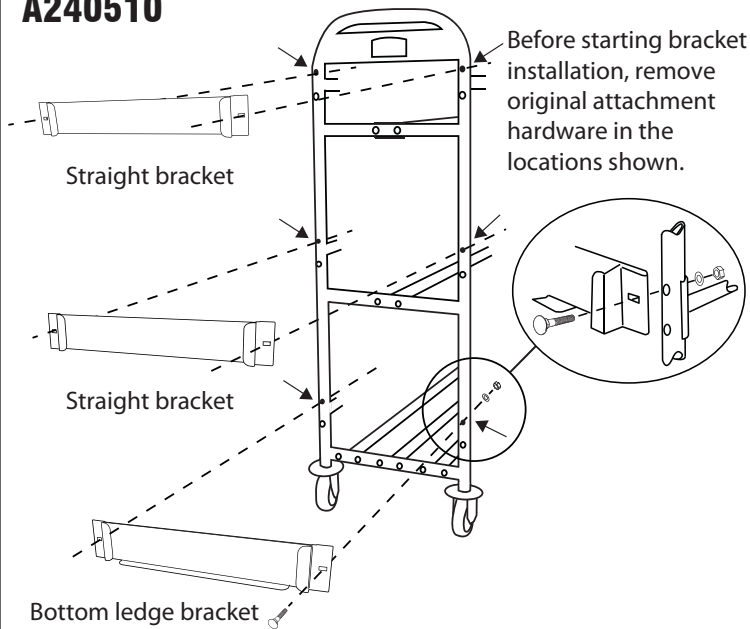

- 1** Starting with an assembled #SMFG2144269 Tote Picking Cart, determine which side of the cart will have the panel bracket kit installed. The brackets and panels can be installed on either narrow end of the cart, with or without the handle.
- 2** Using the wrench, remove the six (6) carriage bolts, washers and nuts at the locations indicated above.
- 3** Starting with the bottom ledge bracket (with the protruding ledge to support the bottom of the advertising panel), line up the slotted holes on each end of the bracket with the round holes in the cart frame.
- 4** Pass the carriage bolt through the bracket, (aligning the square bolt shoulder with the rectangular slot) and round tube. Pass the flat washer over the bolt and loosely screw on the locking nut. Repeat the process on the other side and then using the wrench, tighten the nuts securely.
- 5** Repeat the installation process with two (2) remaining straight brackets.

Installing Half Size Panel Bracket Kit A240511

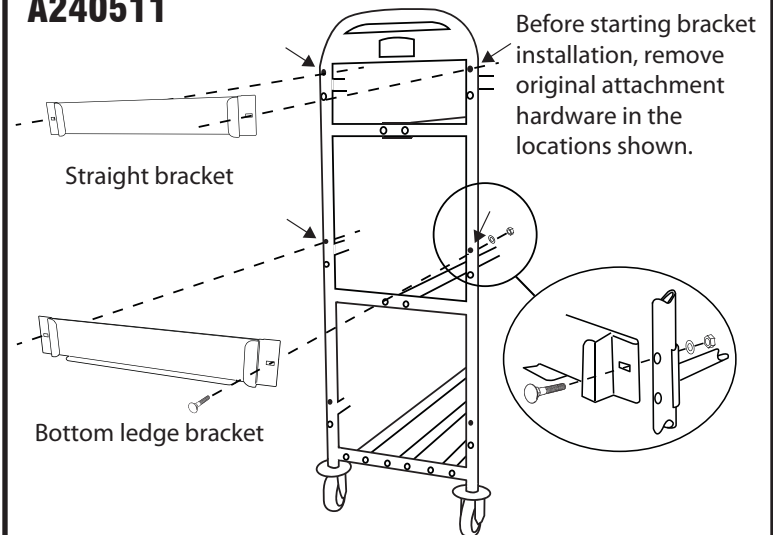

- 1** Starting with an assembled #SMFG2144269 Tote Picking Cart, determine which side of the cart will have the panel bracket kit installed. The brackets and panels can be installed on either narrow end of the cart, with or without the handle.
- 2** Using the wrench, remove the six (4) carriage bolts, washers and nuts at the locations indicated above.
- 3** Starting with the bottom ledge bracket (with the protruding ledge to support the bottom of the advertising panel), line up the slotted holes on each end of the bracket with the round holes in the cart frame.
- 4** Pass the carriage bolt through the bracket, (aligning the square bolt shoulder with the rectangular slot) and round tube. Pass the flat washer over the bolt and loosely screw on the locking nut. Repeat the process on the other side and then using the wrench, tighten the nuts securely.
- 5** Repeat the installation process with one (1) remaining straight bracket.

Advertising Panel Installation

Advertising panels are installed from the top down and retained by tabs on either side of the brackets. Insert the panels from the top down through the brackets until the bottom of the panel rests on the ledge of the bottom bracket.

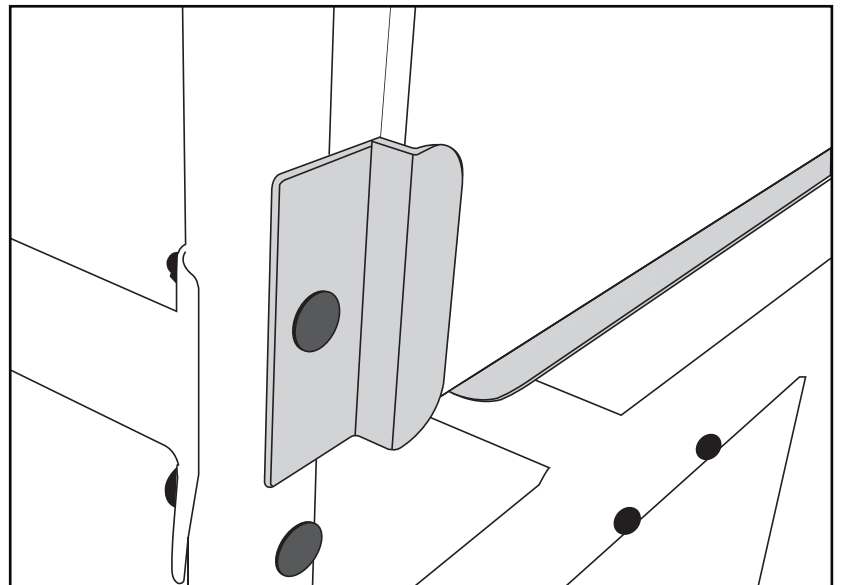
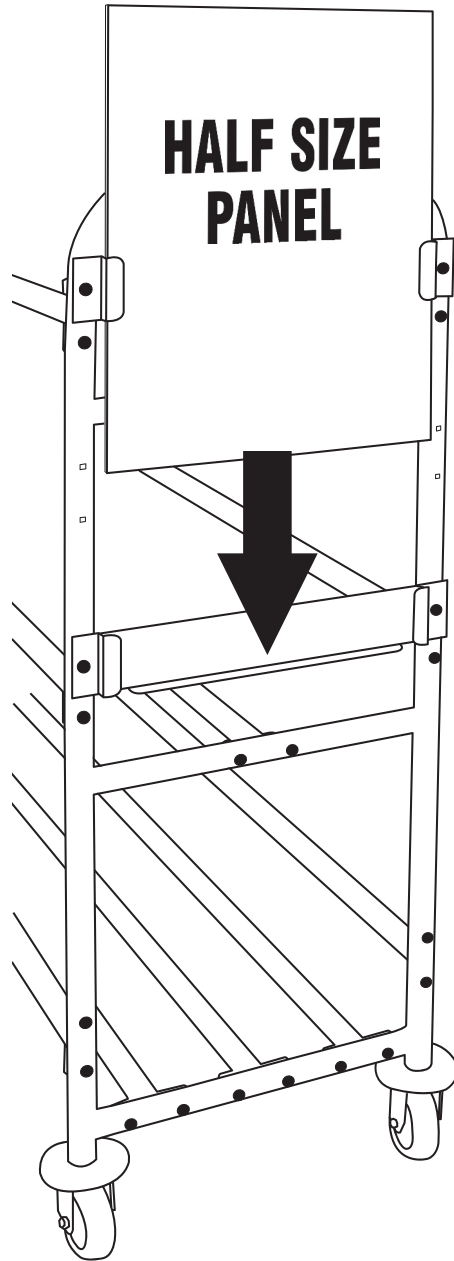
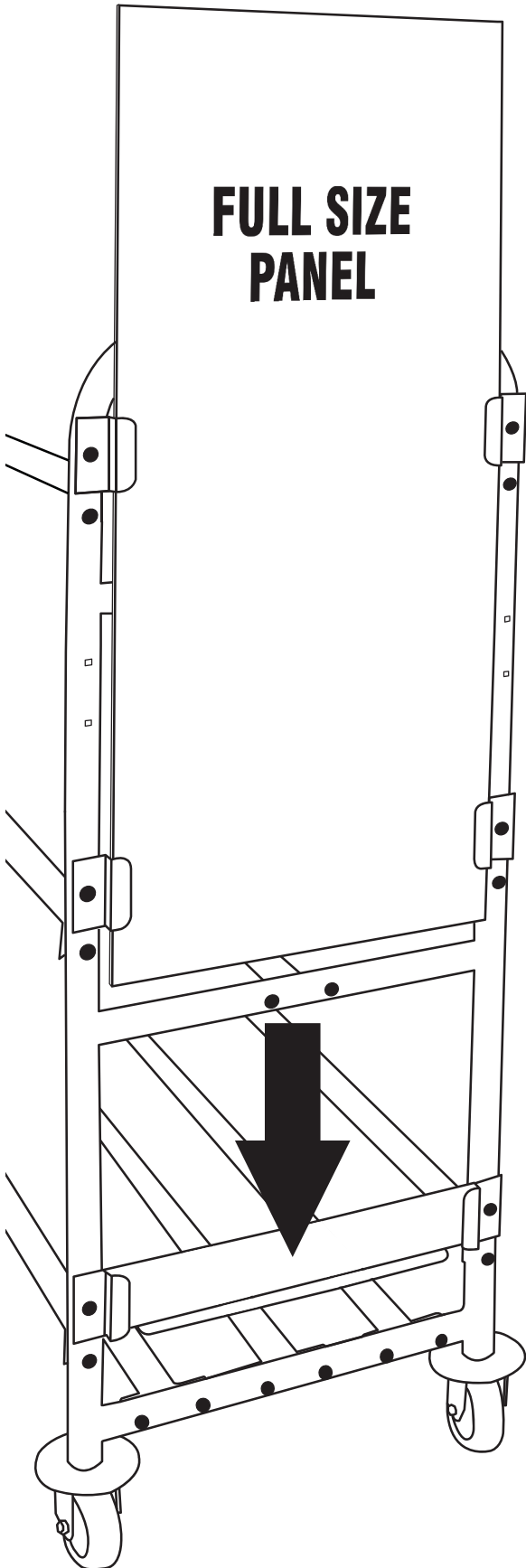

Bottom of panel rests on the bottom ledge bracket.